

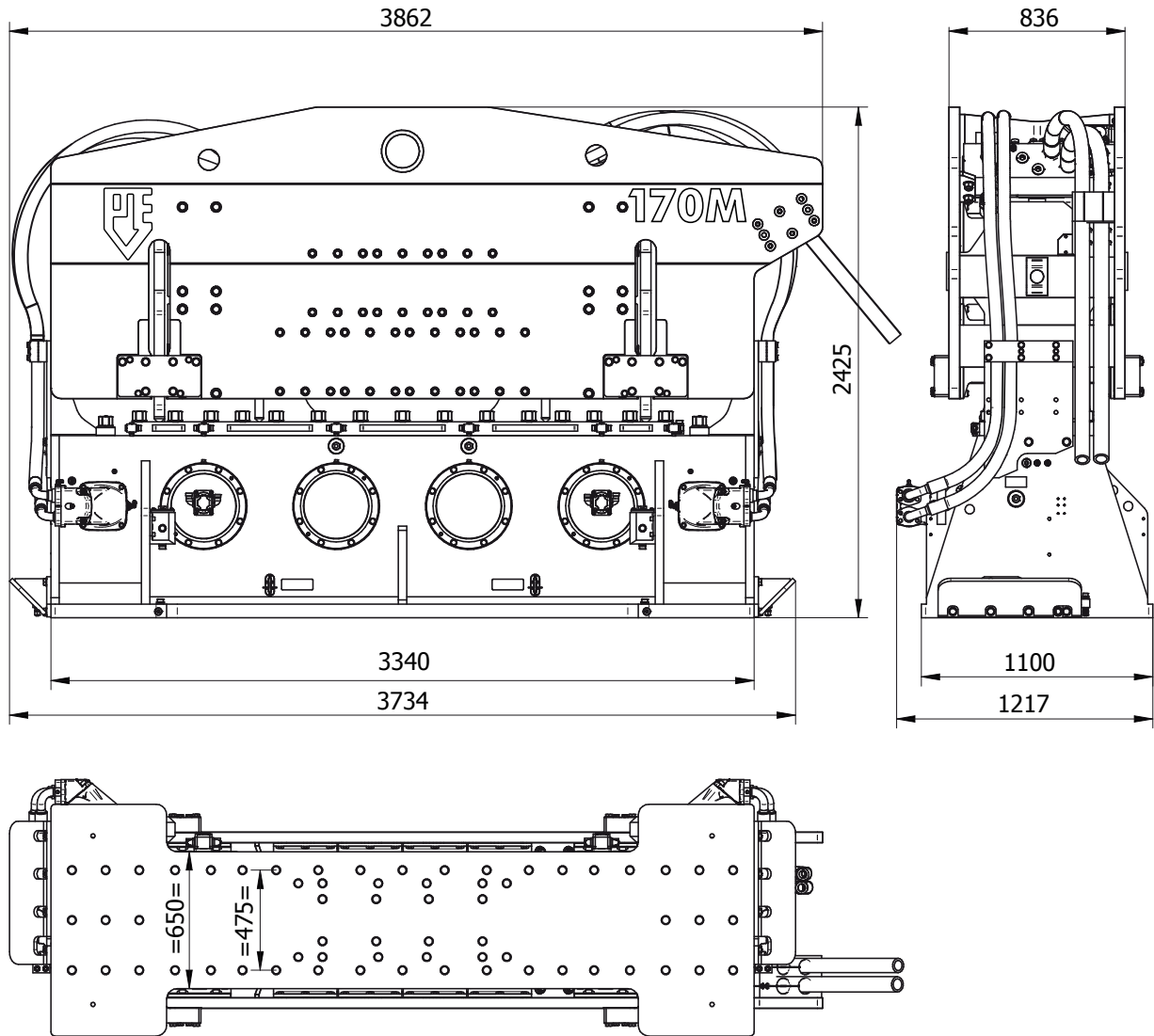

Specification Sheet

PVE 170M

Standard Frequency Vibro Hammer



Specifications

170M

Eccentric moment	14760	inch-lbs	Clamps:	
Max. centrifugal force	411	tons	Double clamps	PPK 350T 2x
Max. frequency	1400	rpm	Transport weight per piece	6570 lbs
Max. amplitude excluding PPK 350T	1.27	inch		
Max. amplitude including PPK 350T	0.81	inch		
Max. static line-pull	142	tons		
Max. operating pressure	5080	psi	Powerpack:	
Max. oil flow	342	gpm	Model	1400
Forced lubrication	yes			
Dynamic weight excluding PPK 350T	23270	lbs	Hose set:	
Dynamic weight including PPK 350T	36410	lbs	Length	148 feet
Total weight excluding PPK 350T & hoses	37590	lbs	Transport weight (±)	2712 lbs